



SP Series Centrifugal Pumps

Service & Installation Manual



Tri-Clover Inc.

CONTENTS

Thank you for purchasing a Tri-Clover Product!

This manual contains disassembly and assembly instructions, maintenance procedures, troubleshooting, and a complete parts list for all SP Series Pumps designed and manufactured by Tri-Clover Inc., Kenosha, Wisconsin.

READ THIS MANUAL carefully to learn how to service these pumps. Failure to do so could result in personal injury or equipment damage.

SAFETY

IMPORTANT SAFETY INFORMATION	4
------------------------------------	---

INTRODUCTION

GENERAL INFORMATION	5
---------------------------	---

INSTALLATION

UNPACKING AND INSTALLATION	6
PIPING HINTS	9

MAINTENANCE

CLEANING	10
SEAL SERVICING	11
TYPE D OR F SEALS - EXTERNAL BALANCED	12
TYPE A AND B PACKING GLAND SEAL	15
TYPE E WATER COOLED BALANCED DOUBLE SEAL	17
FINAL ASSEMBLY	18
PUMP MAINTENANCE AND REPAIR	19
BEARING FRAME	20

TROUBLESHOOTING

TROUBLESHOOTING GUIDELINES	22
----------------------------------	----

PARTS LIST

ALL MODELS	24
------------------	----

SAFETY

IMPORTANT SAFETY INFORMATION

Safety is very important!

DO NOT attempt to modify any Tri-Clover product. To do so could create unsafe conditions and void all warranties. **DO NOT place any Tri-Clover product in an application where general product service ratings are exceeded.**

The following DANGER, WARNING, AND CAUTION signs and their meanings are used within these instructions.

	⚠ DANGER
	Indicates an imminently hazardous situation which, if not avoided, will result in death or serious injury. The word Danger is used in the most extreme cases.

	⚠ WARNING
	Indicates a potentially hazardous situation which, if not avoided, may result in minor or moderate injury. May also be used to alert against an unsafe operating or maintenance practice.

	⚠ CAUTION
	Indicates a potentially hazardous situation which, if not avoided, could result in death or serious injury.

The SAFETY LABEL below is placed on every pump. Do not remove any labeling on any Tri-Clover product. Immediately replace any label that is missing.



Part Number 38-241

INTRODUCTION

GENERAL INFORMATION

GENERAL

This manual contains installation, operation, cleaning, and repair instructions, with parts list, for the SP Series base mounted pumps manufactured by Tri-Clover Inc. of Kenosha, Wisconsin. It also provides a troubleshooting chart to aid in determining pump malfunctions.

	<p style="text-align: center;">▲ WARNING</p> <p>Before servicing pump, disconnect electrical power source.</p>
---	---

DESCRIPTION

The SP Series pump units are generally mounted on base plates which accommodate both the pump units and the drive motors.

The pump units are comprised of two sections, the power frame section which transmits power from the motor to the pump and the liquid end or pump section. The pump impeller is mounted to the power frame shaft and is secured by a floating retainer or by a threaded shaft and castellated nut. The casing is clamped to the power frame, greatly simplifying removal, and permitting positioning of the discharge outlet through 360°.

Three basic standard seal designs, external balanced seal, packing gland, and water cooled balanced double seal, insure long seal life and optimum pump performance for all applications. A wide variety of commercial seals are also available for special applications. Consult the factory for seal parts lists and service instructions.

INSTALLATION

UNPACKING AND INSTALLATION

UNPACKING EQUIPMENT

Check the contents and all wrapping when unpacking your equipment. Inspect all parts for damage that may have occurred during shipping. Report any damage to the carrier.

INITIAL LUBRICATION

Pumps equipped with grease lubricated power frame bearings are lubricated at the factory prior to shipping and will require no additional lubrication until after the pump is put into service.

Pumps equipped with an automatic oiler are shipped dry and must be lubricated prior to initial starting of the pump. Refer to *Lubrication under Pump Maintenance and Repair* later in this manual for more information on lubrication.

INSTALLATION OF AUTOMATIC OILER

The oiler system is comprised of a relief valve, pipe plug, pipe nipple, adapter and the oiler. See Figure One.

Pumps shipped from the factory have the pipe plug and relief valve installed in the inboard and outboard bearing covers, respectively, and the adapter assembled in the power frame reservoir hole. To install the oiler:

1. Screw the pipe nipple into the adapter after applying thread compound to the threads on the nipple.
2. Using a spirit level, check the pipe nipple to make sure it is level as oil will not flow unless the oiler is level.
3. Install the oiler on the nipple with the bottle up.
4. Remove the oiler bottle, fill it with oil, invert the bottle and assemble it to the lower oiler reservoir. Allow the oil to flow into the power frame reservoir.
5. Repeat until the proper oil level is reached in the power frame reservoir and adjust the level adjuster and lock in the lower oiler reservoir as required.

The power frame reservoir should be filled only to the point where the oil is approximately $\frac{1}{16}$ " to $\frac{1}{8}$ " above the inside diameter of the outer bearing race at the lowest point of the bearing. This can be checked by loosening the screws securing the inboard bearing cover and pulling it away from the power frame far enough to permit measuring from the base to the proper level above the outer bearing race. Adjust the oil level in the constant level oiler to this height. The bearing cover should then be returned to its original position and secured.

Note: Excessive oil can cause overheating of the bearing and result in premature failure. Do not overfill the power frame reservoir.

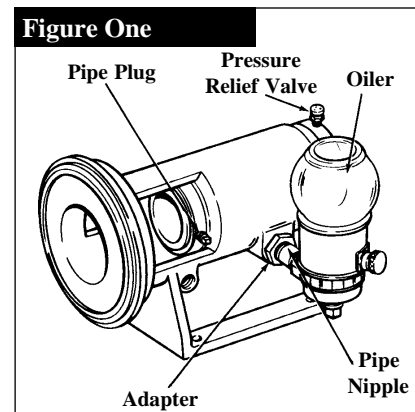

INSTALLATION

LOCATION

The pump unit should be located as near as possible to the liquid source and in a position where the suction piping can be short and direct with a minimum number of elbows and fittings. It should also be readily accessible for inspection, cleaning, and lubrication.

FOUNDATION

The foundation for the pump unit should be heavy enough to absorb any normal vibration and provide a permanent and rigid support at all points of the base plate. A concrete foundation with ample allowance for grouting is most satisfactory. Foundation bolts of the proper size should be placed in a pipe sleeve two to four diameters larger than the bolt to allow movement for final positioning of the base plate. See Figure Two.

Figure Two

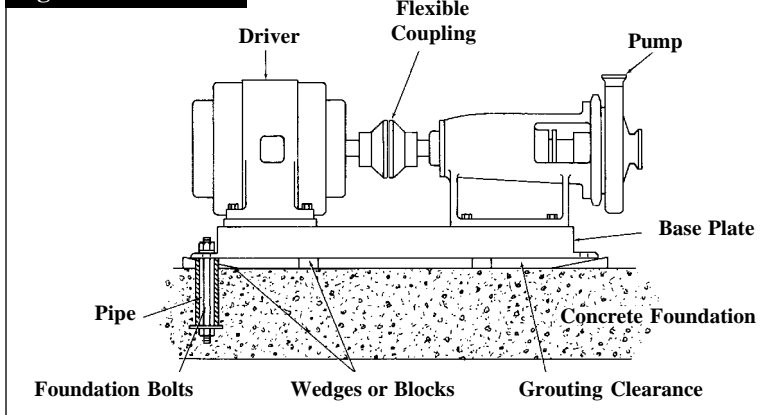

LEVELING THE UNIT

When the unit is received with the pump and drive motor mounted on the base plate, it should be placed on the foundation and the coupling halves disconnected.

The base plate should be supported by blocks or wedges located close to the foundation bolts. Support blocks or wedges should also be provided under the part of the base plate carrying the greatest weight. A gap of $\frac{3}{4}$ " to $1\frac{1}{2}$ " between the bottom of the base plate and the top of the foundation should be allowed for grouting.

Adjust the metal blocks or wedges until the pump and motor shafts are level. Use a level to check the coupling halves and suction inlet for vertical and horizontal alignment. The nuts on the foundation bolts should then be turned down until they are finger tight.

FLEXIBLE COUPLINGS

A flexible coupling compensates for temperature changes and allows end movement of the pump and motor shafts without interference with each other while transmitting power from the motor to the pump. A flexible coupling should not be used to compensate for shaft misalignment. Couplings are properly aligned when the pump, motor and base assembly are shipped from the factory. Alignment may be disturbed during shipping. Couplings must always be realigned before the unit is placed in service.

The faces of the coupling halves should be far enough apart so that they do not touch each other when the motor shaft is moved toward the pump.

The tools required for checking flexible coupling alignment are a straight edge and a taper gauge or set of feeler gauges.

INSTALLATION

FLEXIBLE COUPLING ALIGNMENT

There are two types of misalignment encountered with flexible couplings: angular misalignment and parallel misalignment. To check for angular misalignment and parallel misalignment, insert a taper gauge or feeler gauge at four places located 90° apart around the coupling as shown in figure three. The coupling halves are properly aligned when the measurements are the same at all check points.

To check parallel misalignment, place a straight edge across the coupling half rims at the top, bottom and both sides, making sure that the straight edge is parallel to the motor and pump shafts. See figure four. The coupling are properly aligned when the straight edge rests evenly on the coupling rims at all check points.

Correct alignment is obtained by use of shims under the motor mounting feet. See Figure Five. Adjustments made in one direction may effect alignment in another direction. Therefore several checks of both angular and parallel alignment should be made.

GROUTING

When the alignment procedures have been completed, the foundation bolts should be evenly tightened but not too firmly. The unit can then be grouted to the foundation.

A form should be constructed around the base plate to hold the grout. The base plate should be completely filled with grout, and it may be desirable to grout the support blocks or wedges in place. Do not tighten the foundation bolts until the grout has hardened, usually from 48 to 72 hours after pouring.

FINAL ALIGNMENT

After the grout has hardened, the foundation bolts should be firmly tightened, the suction and discharge piping installed, and a final alignment check made. Be sure the suction and discharge piping is properly supported to avoid any strain on the pump casing.

Note: Check the direction of motor shaft rotation to make sure it is the same as the arrow on the pump before connecting the flexible coupling and starting the pump.

Connect the flexible coupling, and with the pump properly primed, start the pump and operate it until temperatures are stabilized. The unit should then be shut down and the alignment immediately rechecked.

Figure Three

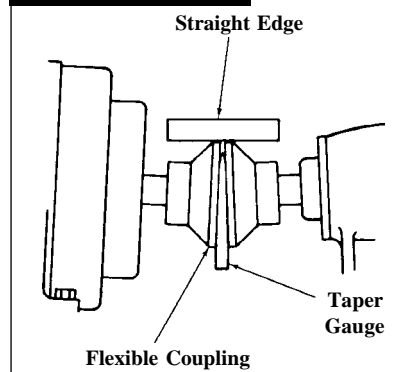

Figure Four

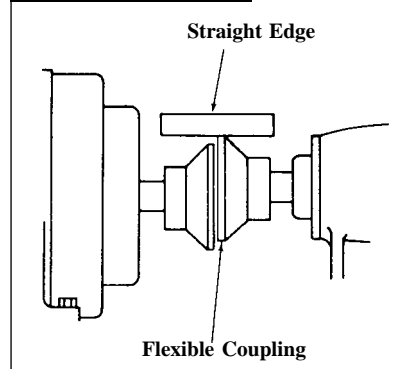
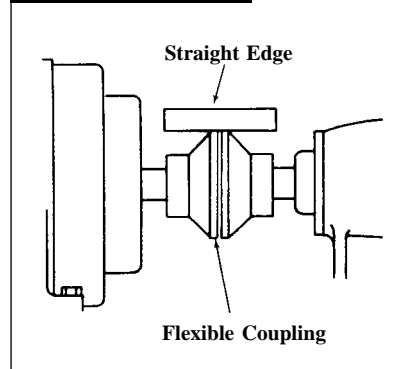

Figure Five



INSTALLATION

PIPING HINTS

GENERAL

This section provides some do's and don'ts of piping which will aid in obtaining the maximum efficiency and service from your pump.

- Piping should be independently supported at both the suction inlet and discharge outlet.
- Care should be taken that piping is properly aligned and does not put any strain on the pump casing.
- The piping should have as few bends as possible.

SUCTION PIPING

- The suction piping should be short and follow a direct route with a minimum number of elbows and fittings.
- Elbows should not be used at the suction inlet as friction would be greatly increased, resulting in head loss.
- Excessive friction losses in the suction line could result in pump cavitation, causing poor performance, noise, vibration, damage to equipment, and possible damage to product.
- Whenever practical, the diameter of the piping at the suction inlet should be increased in size.
- An eccentric tapered reducer should be used in lieu of a straight concentric tapered reducer to prevent air pockets from forming and impairing pump efficiency. In turn, the eccentric reducer may be placed at the inlet of the pump and should be positioned so the straight side is up.
- A horizontal suction pipe must have a gradual rise to the pump. A high point in the suction line will form an air pocket and prevent proper pump operation.
- All joints in the suction line should be air-tight to prevent air leakage which can reduce pump capacity and efficiency.

DISCHARGE PIPING

- The discharge piping should be short and direct with a minimum number of elbows and fittings. It is advisable to increase the pipe diameter at the discharge outlet to minimize head loss.

LOCATING VALVES

- In suction lift applications where a foot valve may be installed to facilitate priming and to prevent draining off of the liquid back to the source.
- A throttling valve should be installed in the discharge piping to provide a means of regulating pump volume.

MAINTENANCE

CLEANING

DISASSEMBLY

	<p style="text-align: center;">⚠ WARNING</p> <p>Before servicing the pump, disconnect electrical power source, carefully relieve all pressure, and drain all fluids from the pump and connected piping.</p>
---	--

It is necessary to disassemble parts of your pump for cleaning and sanitizing. The extent of disassembly will depend on the application and the type of seal used in your pump. For pumps equipped with the “groove in shaft” design, it is not necessary to disassemble if used in a clean-in-place installation.

To disassemble:

1. Disconnect the suction and discharge piping.
2. Turn the wingnut on the clamp assembly until tension on the clamp saddle is relieved.
3. Open the saddle and remove the casing.
4. On pumps with the floating impeller retainer:
 - a. Rotate the impeller until the retainer is in a horizontal position.
 - b. Push back on the impeller and center the retainer in the shaft.
 - c. Slide the impeller forward and remove it.
5. On pumps with threaded shaft and castellated nut, remove cotter pin and turn castellated nut in counterclockwise direction, and remove washer and impeller. Pumps equipped with packing glands do not require further disassembly for cleaning.

Refer to the *Seal Servicing* section of this manual for disassembly and reassembly of the seal installed in your pump.

MAINTENANCE

SEAL SERVICING

GENERAL

There are six standard seal types available for the SP Series pumps. Others are available as options.

To gain access to the seal components it will be necessary to remove the casing clamp, casing, and impeller. Impeller removal procedure will vary, depending on the retention system applicable to your pump.

DISASSEMBLY

Floating Retainer Pin Models

1. Rotate the shaft until the retainer pin hole is horizontal.
2. Push back on the impeller and center the pin in the shaft.
3. Slide the impeller forward off the shaft. Do not try to remove the retainer before removing the impeller as this may cause damage to the retainer, shaft and impeller.

Threaded Shaft Models

1. Remove the cotter pin and turn the castellated nut in a counterclockwise direction.
2. Remove the washer(s) and impeller.

REASSEMBLY

Floating Retainer Pin Models

1. Rotate the shaft until the retainer pin hole is horizontal. Insert the retainer, center it in the shaft, and slide the impeller on.
2. Hold the impeller tight against the shoulder on the shaft and rotate it one-fourth turn until the pin drops and engages the impeller.

Threaded Shaft Models

1. Slide the impeller on the shaft, replace the washer(s) and tighten the castellated nut.
2. Verify that the cotter pin hole in the shaft is in alignment with one of the slots in the nut. If not, proper alignment must be obtained by adding or removing No. 133 washers from between the nut and the impeller face. Washers are available in thicknesses of .005" and .010" to facilitate.

MAINTENANCE

TYPE D OR F SEALS - EXTERNAL BALANCED

GENERAL



WARNING

Before servicing the pump, disconnect electrical power source, carefully relieve all pressure, and drain all fluids from the pump and connected piping.

The D and F balanced seals are identical except that the F seal has a water cascade provision.

The DG and FG types are similar, but incorporate a replaceable clamped-in stationary seal seat. The FG has a water cascade.

A balanced design utilizes pump internal pressure to aid the seal spring in maintaining seal contact with the backplate.

The seal is centered on the pump shaft by a recess that pilots on the nose of the drive collar. The recess also accommodates an o-ring that prevents fluid leakage from the rear of the seal.

Torque is transmitted by tabs on the seal cup that engage slots on the seal periphery and by another slot that engages a lug on the drive collar.

The seal should be replaced when the clearance between the carbon seal face and the stationary seal surface is less than $1/32$ " or when leakage is observed.

DISASSEMBLY

1. Disconnect piping.
2. Remove the casing clamp, casing and impeller.
3. Rotate the backplate to disengage the hooks that secure it to the pump frame and remove. The seal rotating components will now be accessible.

INSPECTION

Examine the seal rotating and stationary sealing surfaces for nicks, scratches or other damage and replace as necessary.



Inspect the o-ring for abrasions, cuts and resiliency. Replace if defective.

The pump shaft should be unworn and free of nicks and scratches, especially in the area of the seal o-ring contact.

MAINTENANCE

REASSEMBLY

DG and FG stationary seats are reversible as supplied by the factory. To reverse, remove the four capscrews that secure the gland ring to the backplate and lift off the gland ring. The stationary seat can be turned over to bring the unused surface into use.

	 CAUTION
	<p>(except for SP4410 models) Teflon gaskets having different thicknesses are used. The thicker gasket must always be installed on the impeller side to prevent contact between the impeller hub and the stationary seat. Position the gland ring over the seat, install the capscrews, and tighten. Always use lockwashers under the capscrew heads.</p>

If the seal has been replaced or the drive collar loosened, it will need to be repositioned. Two methods are available.

EXTERNAL BALANCED SEALS - SETTING SEAL DRIVE COLLAR BY MEASUREMENT

1. Install the backplate, gasket and casing.
2. Install and tighten casing clamp.
3. At a location behind the backplate scribe a mark on the shaft. See Figure Six or Figure Seven.
4. Remove casing clamp, casing and backplate.
5. Slide the drive collar onto the shaft.
6. Locate drive collar in relation to the scribe mark as shown in dimension A and secure to the shaft with the set screws. Drive collar location is critical.
7. Install the seal spring, seal cup, seal o-ring and carbon onto the shaft.

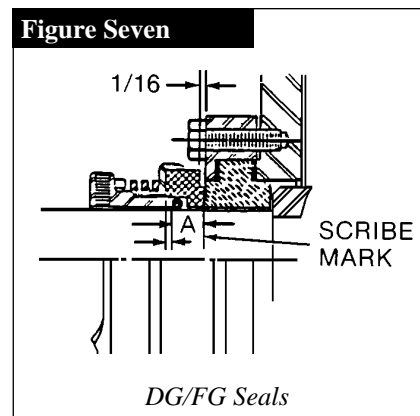
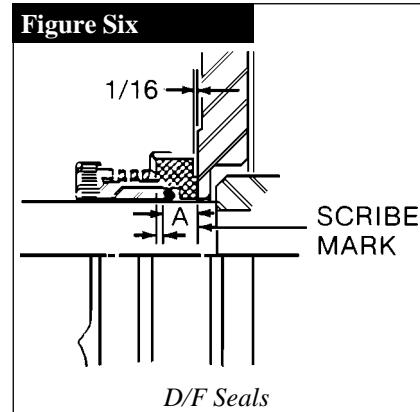

Model	"A" Dimension
SP114	$11/32$
SP216	$11/32$
SP218	$11/32$
SP328	$11/32$
SP4410	$11/32$

MAINTENANCE

EXTERNAL BALANCED SEALS - SETTING THE DRIVE COLLAR BY POSITION

1. Assemble the spring, seal cup, o-ring seal and carbon seal onto the drive collar. Care must be taken so that the spring does not rest on the tab that is bent back. A portion of the spring is offset to provide clearance for this tab. Care must also be taken to ensure that pin on drive collar is in line with the slot on the cup.
2. Install as a unit on the shaft.
3. Install the backplate and casing.
4. Install and tighten the casing clamp.
5. Slide the drive collar and seal assembly toward the backplate until the nose of the drive collar pushes the o-ring and carbon seal tight against the backplate.
6. Slide the drive collar away from the backplate $\frac{1}{32}$ " and secure the drive collar in this location with the setscrews.

When the drive collar is properly positioned and seal components are properly installed, the pump shaft should rotate freely by hand. If excessive effort is required to rotate the shaft, check to be sure that all components are properly installed and that the drive collar is properly positioned.

MAINTENANCE

TYPE A AND B PACKING GLAND SEAL

SEAL REPLACEMENT

The packing gland seals are used in non-sanitary applications. They are available in two styles: standard packing and water cooled packings. The packings have been designed to give long life and service free operation. Each packing ring serves a definite purpose and is made to properly "fit" around the shaft. The packing rings are impregnated to provide lubrication to the surface of the pump shaft and prevent burning of the packing.

The packing gland seal with water contains a seal cage inserted between the packing rings to distribute coolant under pressure in both directions, thus sealing the packing along the shaft, and reducing operating temperatures.

It is not necessary to remove the backplate, which also forms a stuffing box, from the pump to replace packings. To replace packings:

1. Remove the split gland nuts and split glands.
2. Remove the old packings using a packing hook or other suitable tool.
3. Insert new packing rings into the backplate.

Notes: The packing rings are die formed and must be carefully handled.

The packing rings furnished by Tri-Clover are in a package. The first ring of the packing is tagged, and the remainder of the rings are to be installed as they are assembled in the package. The packing rings should be twisted laterally until they slide over the shaft. The joints in the packing rings should be staggered to minimize leakage.

4. Replace the split gland and nuts.
5. Tighten the split gland nuts only until a slight drag is felt on the shaft. If the packings are too tight they will bind on the shaft causing scoring of the shaft and burning of the packing.

After packing installation, the pump should be brought up to operating temperature, and the split glands adjusted several times to prevent excessive leakage. The packing gland seal with water should drip water from the stuffing box at a rate of 8 to 12 drops a minute for best results.

DISASSEMBLY

	⚠ CAUTION
	Before servicing the pump, disconnect electrical power source, carefully relieve all pressure, and drain all fluids from the pump and connected piping.

1. Remove the two nuts securing the packing gland to the backplate.
2. Remove the split packing gland.
3. Slide the backplate containing the packing rings off the shaft.
4. Remove the casing gasket.

Note: The packing rings are accurately die formed. Care should be taken when removing the bakplate so that the packing rings are not damaged.

MAINTENANCE

INSPECTION

Carefully inspect the packing rings for cuts, wear and signs of scorching caused by excessive tightening of the gland nuts. Replace the complete packing set if required. Inspect the stuffing box and backplate for cracks and other damage that can shorten seal life. Inspect the shaft for scoring or wear caused by too tight packing or the wrong type of packing.

REASSEMBLY

Assemble the packing rings in the stuffing box portion of the backplate making sure the ring joints are staggered.

Note: The packing rings are accurately die formed and must be handled carefully.

Slide the backplate onto the shaft, being careful not to damage the packing rings. Assemble the split gland to the backplate, tightening the nuts only until there is a slight drag on the shaft.

Note: Tightening the gland too tight will cause burned packing rings and scored shafts.

Assemble the water line to the backplate if your pump is so equipped.

MAINTENANCE

TYPE E WATER COOLED BALANCED DOUBLE SEAL

DISASSEMBLY



⚠ WARNING

Before servicing the pump, disconnect electrical power source, carefully relieve all pressure, and drain all fluids from the pump and connected piping.

Pumps equipped with a Type E seal can be readily disassembled by the following procedure.

1. Disconnect the seal flush piping and remove the seal guard.
2. Loosen the four capscrews that secure the follower to the stuffing box.
3. Back out the capscrews until the follower is loose. It may be under pressure from the seal spring. If so, restrain it by hand until all the capscrews have been removed.
4. Remove the casing clamp, casing, impeller and casing gasket.
5. Carefully slide the backplate assembly forward off the pump.
6. The seal rotating components will now be accessible. The seal drive collar can be removed by loosening two set screws.
7. All seal parts then can be removed by sliding them forward off the shaft.

INSPECTION

Examine the seal rotating and stationary sealing surfaces for nicks, scratches, or other damage and replace as necessary.

Inspect the o-rings for abrasions, cuts and resiliency. Replace if defective.

Normally, the seal spring, drive collar and cups will not require replacement. They should, however, be inspected for mechanical damage and be replaced if needed.

Figure Eight

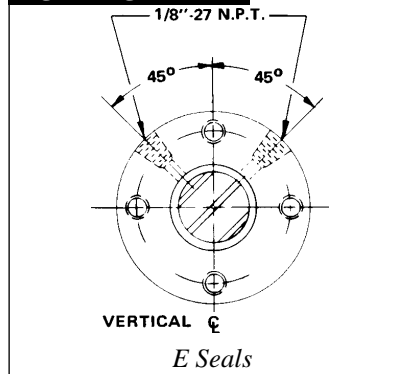
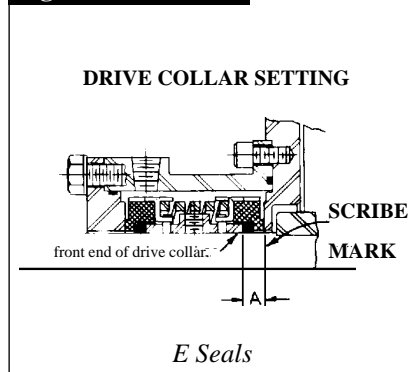

Figure Nine



Model	"A" Dimension
SP114	11/32
SP216	11/32
SP218	11/32
SP328	11/32
SP4410	11/32

MAINTENANCE

REASSEMBLY

1. To determine the drive collar setting, assemble the backplate (less stuffing box), casing gasket, casing and casing clamp. The impeller need not be installed at this time.
2. Scribe a mark on the shaft as shown in Figure Nine.
3. Disassemble.
4. Verify that the follower o-ring is in place and slide the follower onto the shaft. Also slide the rear carbon seal, seal o-ring, and cup onto the shaft.
5. Slide the drive collar onto the shaft.
6. Lock in place with the set screws at "A" dimension from the previously scribed line.
7. Install the seal spring, front cup, front seal o-ring and front seal carbon.
8. At this time position both cups so that the drive tabs engage the slots on the carbons. Also, on the inner diameter of the cups there are tabs bent at 90° to the plane of the cup. These must be positioned so that they are not directly in line with the pins on the drive collar.
9. Slide the two seals toward each other so that the spring nests in the cups.
10. Assemble the stuffing box to the backplate, verifying that the o-ring is in place in the groove in the front flange.
11. Carefully position the backplate and the stuffing box over the seal assembly.
12. Position the backplate in the recess in the bearing frame and hold in place.
13. Move the follower forward and secure with capscrews. These should be tightened evenly so that the follower remains essentially perpendicular to the shaft. Install the casing gasket and/or orient the backplate so that the flush ports are positioned as shown in Figure Eight.

FINAL ASSEMBLY

For all Seal Types:

1. Assemble the impeller, casing, and casing clamp ascertaining that the "V" section of the clamp fits over the mating surfaces of the casing and bearing frame.
2. Tighten the clamp wing nut. (Tapping the clamp with a soft hammer while tightening will help to seal it.)
3. Rotate the shaft by hand. It should turn smoothly with no rubbing or binding.
4. Assemble the seal guard and install the seal flush piping.

MAINTENANCE

PUMP MAINTENANCE AND REPAIR

LUBRICATION

The only maintenance on your SP pump other than cleaning and sanitizing is periodic lubrication of the power frame bearings, seal replacement and inspection of the pump components. Lubrication of the liquid end section is not required as the pump relies on the process fluid for lubrication.

LUBRICATION OF POWER FRAME BEARINGS

The bearings in the power frame are lubricated in one of two ways; either by greasing which is standard, or by an optional oil feed system. The method you use has been determined by your specific pump application.

Grease Lubrication

The power frame bearings should be greased at regular intervals. Mobile Oil Corporation's "Mobile Temp SHC32" grease or equivalent is recommended. Mixing of different brands of grease should be avoided to prevent possible chemical reactions between the brands which could damage the bearings. Greases containing vegetable or animal bases should not be used because they can develop harmful acids. Also avoid using greases containing graphite, rosin, talc and other impurities.

Old grease, forced out of the bearings by new grease during lubrication, accumulates in the reservoir in the power frame housing. Because of the design of the grease lubrication system, the bearings will pump excess grease into the grease reservoir between the bearings. A pipe plug in the power frame is provided for removing old grease from the power frame reservoir.

Note: Be sure the lubrication fittings are wiped clean before greasing to prevent dirt from being forced into the bearings during greasing.

If your pump has been operated under extremely dusty or wet conditions for several months or has been idle for a long period of time, the bearings should be cleaned thoroughly with nonflammable solvent and new grease applied. Refer to the applicable paragraphs for disassembly, cleaning and inspection procedures.

Oil System Lubrication

The automatic oiling system utilizes a glass or plastic bottle filled with oil which replenishes the supply of oil in the power frame reservoir if it reaches a level lower than what the system is set for. When the bottle is empty, refill it with oil. A good grade of SAE 20 oil is recommended.

Do not supply too much oil. An excessive amount of oil in the reservoir can cause overheating of the bearing and result in bearing failure.

Periodically, the oil should be drained from the power frame reservoir to prevent buildup of dirt, metal chips, and extraneous material that could possibly damage the bearings or oil seals. Refer to the disassembly section for disassembly procedures.

Grease to Oil Conversion

It is possible to convert your pump from the standard grease lubrication to the optional oiler system. To convert, you must disassemble the power frame and thoroughly clean the power frame reservoir, bearing covers and bearings to remove any trace of grease, per the applicable maintenance and repair instructions contained in this manual. For installation of the automatic oiler system, refer to the instructions accompanying the oiler, and the topic *Installation of Automatic Oiler* on page 6 of this manual.

MAINTENANCE

BEARING FRAME

DISASSEMBLY

Disassembly is uniform for all SP Series pumps.

1. Remove the screws from the outboard and inboard bearing covers.
2. Remove the outboard bearing cover and shims.
3. Drive the shaft and bearings through the housing from the impeller end using a soft hammer. If a soft hammer is not available, a block of wood should be used to protect the end of the shaft. Note carefully the location of the brass shims on one side or the other of the outboard bearing. The shims must be installed in the same location when reassembling.

No further disassembly is recommended unless inspection shows that replacement of bearings or grease seals is required. If bearings are to be replaced:

1. Bend back the prong on the outboard bearing retaining washer.
2. Remove the outboard bearing nut and retaining washer. If a spanner wrench is not available for removing the nut, a soft blunt implement should be inserted in the slot in the nut and tapped with hammer until the nut loosens and can be removed.
3. Using a bearing puller, or arbor press remove the damaged bearing(s) from the shaft.
4. If grease seals need replacement, press or drive them out of the bearing covers.

INSPECTION

1. Remove the drain plug from the power frame. If your pump is equipped with an oiler, and it is desirable to drain the power frame reservoir, remove the oiler from the power frame.
2. Remove any accumulation of grease from the inside of the power frame.
3. Reassemble the drain plug or install the oiler as applicable.
4. Inspect the power frame for cracks or other damage that could impair function of the pump.
5. Clean the outside of the power frame, shaft, and bearing covers with a clean rag soaked in nonflammable solvent and flush all surfaces.
6. Flush the inside of the power frame with nonflammable solvent to remove any harmful material from the power frame reservoir. Dry with compressed air or allow solvent to evaporate.

Note: Clean impeller end of the shaft thoroughly after reassembly to remove any solvent that could contaminate the process fluid.

7. Inspect the shaft carefully for nicks or scratches that can damage the grease seals or the o-ring seal at the liquid end. Remove small nicks or scratches with fine file or emery cloth.
8. Examine the bearing covers, casing and impeller for cracks or other signs of excessive wear.

MAINTENANCE

REASSEMBLY

If it is necessary to replace the bearings:

1. Press the bearing onto the shaft, making sure that the double row bearing is toward the liquid end of the shaft. Refer to figure ten.
2. Install the retaining washer and locknut, tightening locknut until the outboard bearing is firmly seated against the shoulder of the shaft.
3. Bend prong of retaining washer into slot on the locknut.
4. If the shims were located between the shoulder in the power frame and the outboard bearing, they must be installed prior to installing the shaft in the power frame.
5. Start the shaft through the power frame.
6. When it is through the power frame, slide the inboard bearing cover onto the shaft being careful not to damage the grease seal.
7. Start the bearings in their bores and tap the shaft firmly with a soft hammer until the bearings are firmly seated.
8. Install shims between the outboard bearing cap and the power frame. Refer to figure ten. Assemble the inboard and outboard bearing covers to the power frame.
9. Lubricate the bearings using approximately $\frac{1}{2}$ ounce of recommended grease per bearing.
10. Slide the rubber slinger on the shaft and seat it near the inboard bearing cover. The slinger should not rub on the bearing cover.

Figure Ten

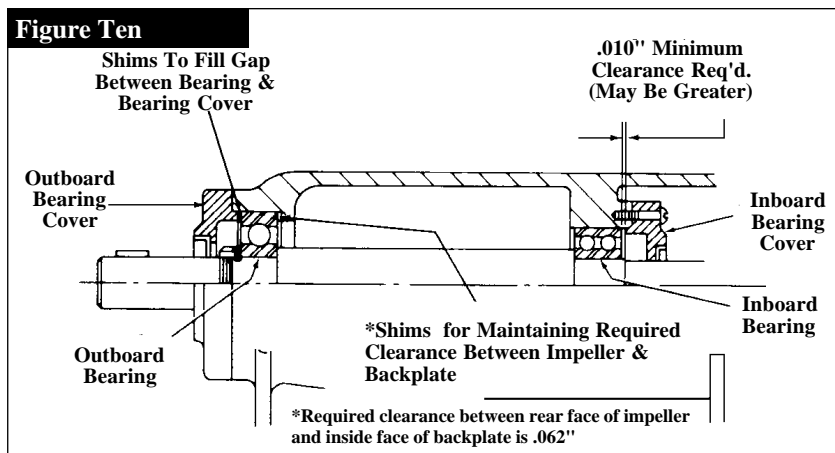

TROUBLESHOOTING

TROUBLESHOOTING GUIDELINES

Tri-Clover pumps are relatively maintenance free with the exception of sanitizing and lubrication. Like any piece of machinery, however, occasional problems can arise. The troubleshooting chart provides a means of determining and correcting most of your pump problems. The motor manufacturer should be contacted for specific repair instructions on the motor.

Note: The troubleshooting chart has been prepared on the basis that the installed pump has been properly suited to its application. Should problems arise where the remedies listed in the troubleshooting chart do not cure the situation, pump cavitation may be the problem. Symptoms of pump cavitation, such as noisy operation, insufficient discharge, and vibration, can result when a pump is not properly applied. If these conditions are present, check the system and reevaluate the application. For assistance, contact Tri-Clover.

PROBLEM	PROBABLE CAUSE	REMEDY
1. No discharge connections	<ul style="list-style-type: none"> a. Pump speed too slow. b. Wrong direction or rotation. c. Closed valve. d. Obstruction in discharge piping. 	<ul style="list-style-type: none"> a. Correct wrong or poor electrical b. Reverse a three-phase motor by switching any two of three power leads at the motor or controller. c. Open valve. d. Clear obstruction.
2. Insufficient discharge	<ul style="list-style-type: none"> a. Pump speed too slow. b. Wrong direction of rotation. c. Valve partially closed. d. Obstruction in discharge piping. e. Impeller damaged. f. Air leak in suction line. g. Air leak through stuffing box. h. Cavitation 	<ul style="list-style-type: none"> a. See 1.a. above. b. See 1.b. above. c. See 1.c. above. d. See 1.d. above. e. Replace impeller. f. Check suction line joints. g. Replace worn or burned packings; check stuffing box for out of round condition. h. See note above.
3. Excessive power consumption	<ul style="list-style-type: none"> a. Motor speed too high. b. Impeller is binding. c. Motor shaft is bent or worn. d. Power frame shaft is bent or worn. e. Power frame bearings are worn. f. Packings are too tight. g. Excessive misalignment between pump and driver. 	<ul style="list-style-type: none"> a. Internal motor wiring is incorrect. Replace motor; check line voltage. b. Relieve strain on casing; replace defective impeller. c. Have motor serviced or replaced. d. Replace shaft. e. Replace bearings. f. Loosen packing gland; replace packing if required. g. Align pump and driver.

TROUBLESHOOTING

PROBLEM	PROBABLE CAUSE	REMEDY
4. Pump is noisy.	<ul style="list-style-type: none"> a. Magnetic turn. b. Motor bearings are worn. c. Foreign matter is rotating with impeller. d. Impeller is binding. e. Motor shaft is bent or worn. f. Power frame shaft is bent or worn. g. Power frame bearings are worn. h. Excessive misalignment between pump and driver. i. Cavitation. 	<ul style="list-style-type: none"> a. Consult motor manufacturer. b. Replace bearings. c. Remove casing and remove foreign matter. d. See 3.b. on previous page. e. See 3.c. on previous page. f. See 3.d. on previous page. g. See 3.e. on previous page. h. See 3.g. on previous page. i. See note on previous page.
5. Excessive vibration	<ul style="list-style-type: none"> a. Pump is not leveled properly. b. Excessive misalignment c. Impeller is damaged. d. Piping is not supported. e. Power frame shaft is bent or worn. f. Cavitation. 	<ul style="list-style-type: none"> a. Level pump. b. See 3.g. on previous page. c. Replace impeller. d. Support discharge and suction piping. e. See 3.d. on previous page. f. See note on previous page.
6. Pump leaks.	<ul style="list-style-type: none"> a. Seal is worn or defective. b. Insufficient tension on seal assembly. c. Damaged inlet or outlet. d. Backplate gasket is worn. e. Clamp is loose. 	<ul style="list-style-type: none"> a. Replace seal. b. Replace spring; adjust packing gland. c. Replace casing. d. Replace gasket. e. Tighten clamp.

PARTS LIST

ALL MODELS

All orders for repair parts must contain the following data.

1. Complete model number (located on nameplate).
2. Pump serial number (located on nameplate).
3. Description and part number from parts list.

The exploded views and accompanying parts list facilitate ordering repair parts from the factory. All parts of the pump are exploded and keyed to the parts list.

KEY	DESCRIPTION	QTY	KEY	DESCRIPTION	QTY
1	Casing	1	47	Bearing Seal (Inboard)	1
2	Impeller	1	49	Bearing Seal (Outboard)	1
6	Shaft	1	69	Lockwasher	1
6B	Threaded Shaft	1	71A	Adapter Pin (External Seal)	1
11A	Backplate (Packing Seal)	1	75	Clamp Assembly - Complete	1
11B	Backplate (Packing-Water Seal)	1	77	Elbow	2
11D	Backplate (External Seal)	1	80	Carbon Seal-(E Seal Takes 2)	1
11F	Backplate Pin (D Seal)	2	80A	Cup	1
11G	Backplate (E Seal)	1	80B	O-ring, Seal-(E Seal Takes 2)	1
11H	Backplate (DG Seat)	1	80C	Spring	1
13	Packing	1	80D	Drive Collar	1
16	Bearing (Inboard)	1	80E	Set Screw	2
17	Split Gland	1	80F	Cup	2
17A	Nut (Split Gland)	2	80G	Spring	1
17B	Stud (Split Gland)	2	80H	Drive Collar	1
17F	Follower (E Seal)	1	80I	Set Screw	1
17G	Machine Screw	1	80N	Seal Seat	1
17H	O-ring	1	80P	PTFE Gasket (Outboard)	1 or 2**
17I	Lockwasher	4	80R	PTFE Gasket (Inboard)	1**
17J	SS Gland Ring	1	83	Stuffing Box	1
17K	Bolt/Screw	4	83A	Machine Screw	4
17M	Lockwasher	4	83B	O-ring	1
18	Bearing (Outboard)	1	85	Slinger	1
19	Frame	1	90	Casing Gasket	1
22	Locknut (Shaft)	1	92	Shims (Bearing)	+
24	Retainer (Impeller)	1	125	Oiler	1
24A	Castellated Nut (Impeller)	1	125A	Pressure Relief Valve	1
24B	Cotter Pin (Impeller)	1	125B	Pipe Plug	1
29	Seal Cage	1	125C	Reducer	1
35	Bearing Cover (Inboard)	1	125D	Nipple	1
37	Bearing Cover (Outboard)	1	127	Water Inlet Assembly	1
37A	Bearing Cover Screw	8	127A	Locknut	1
44	Grease Fitting	2	131	Seal Guard	1
46	Coupling key	1	131A	Seal Guard Cap Screw	1
			131B	Seal Guard Nut	1
			133	Washer (Impeller)	1

+ Number of bearing shims required can vary.

** Model 114/216/218/328 req. 1-#80P outboard gasket (1/16" thick), and 1-#80R inboard gasket (1/8" thick). Gaskets are not interchangeable. Model 4410 req. 2-80P gaskets (same size out/inboard).

SP Series Pump with Floating Retainer

Threaded Shaft and Castellated Nut Retainer System for Use with Type D, F or E Seals

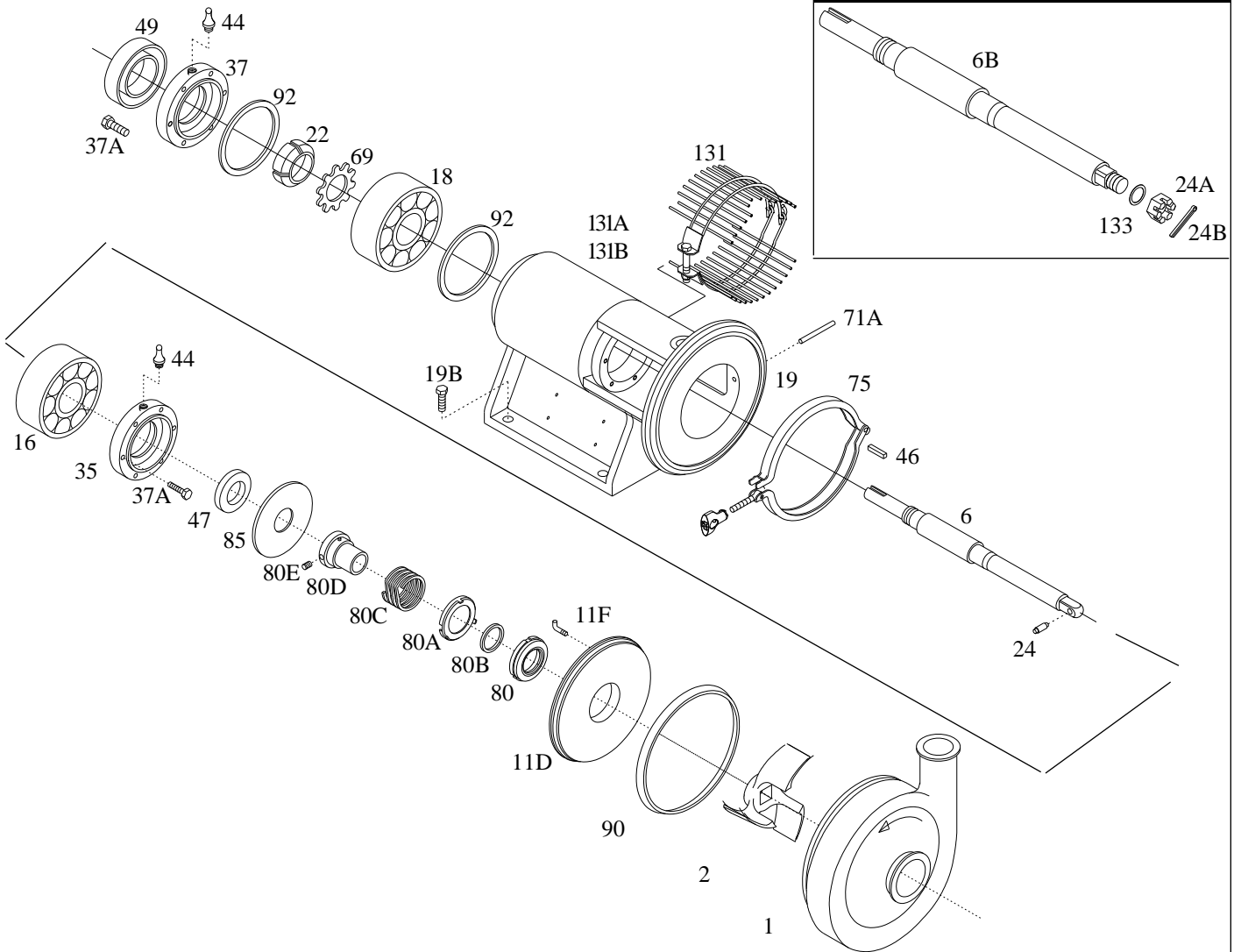

Type E Water Cooled Balanced Double Seal

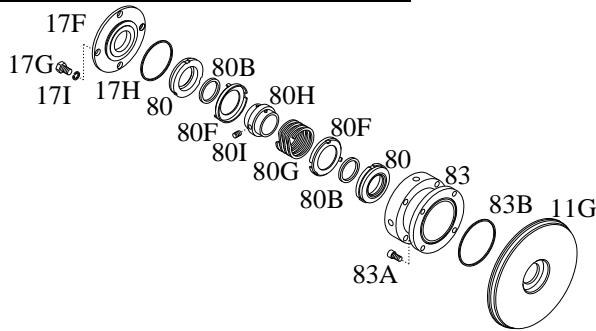

Optional Power Frame Oiler

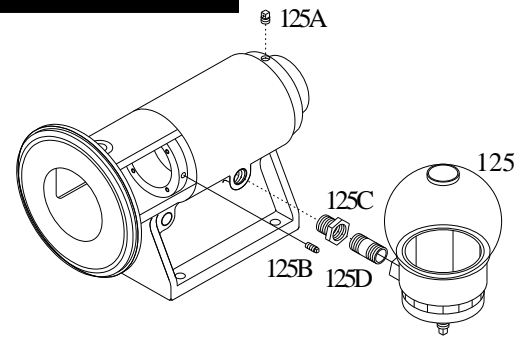

A Packing Gland Seal

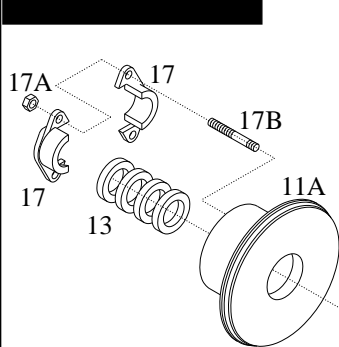

B Packing Gland Seal with Water

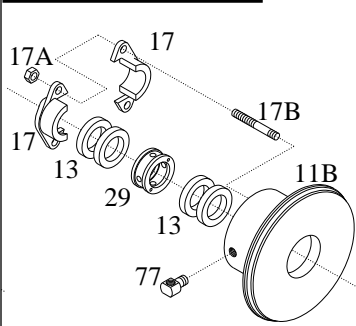

F External Seal with Water Flush

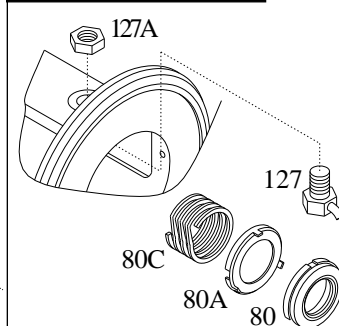

Additional Type DG Clamped-in Seal Seat Components (For use with type D seal)

